

# Mark bass

OWNER'S MANUAL

**Mark Vintage Pre**

## IMPORTANT SAFETY INSTRUCTIONS

- 1) Read these instructions;
- 2) Keep these instructions;
- 3) Heed all warnings;
- 4) Follow all instructions;
- 5) Do not use this apparatus near water;
- 6) Clean only with dry cloth;
- 7) Do not block any ventilation openings. Install in accordance with the manufacturer's instructions;
- 8) Do not install near any heat sources such as radiators, heat registers, stoves, or other apparatus (including amplifiers) that produce heat;
- 9) Do not defeat the safety purpose of the polarized or ground-type plug. A polarized plug has two blades with one wider than the other. A grounding type plug has two blades and a third grounding prong. The wide blade or the third prong are provided for your safety. If the provided plug does not fit into your outlet, consult an electrician for replacement of the obsolete outlet;
- 10) Protect the power cord from being walked on or pinched, particularly at plugs, convenience receptacles, and the point where they exit from the apparatus
- 11) Only use attachments/accessories specified by the manufacturer;
- 12) Use only with the cart, stand, tripod, bracket, or table specified by the manufacturer, or sold with the apparatus.  
When a cart is used, use caution when moving the cart/apparatus combination to avoid injury from the tip-over (and Fig 21 DU Tipping Cart Symbol).
- 13) Unplug this apparatus during lightning storms or when unused for long periods of time;
- 14) Refer all servicing to qualified service personnel. Servicing is required when the apparatus has been damaged in any way, such as power supply cord or plug is damaged, liquid has been spilled or objects have fallen into the apparatus, the apparatus has been exposed to rain or moisture, does not operate normally, or has been dropped;
- 15) "WARNING: TO REDUCE THE RISK OF FIRE OR ELECTRIC SHOCK, DO NOT EXPOSE THIS APPARATUS TO RAIN OR MOISTURE AND OBJECTS FILLED WITH LIQUIDS, SUCH AS VASES, SHOULD NOT BE PLACED ON THIS APPARATUS".
- 16) TO COMPLETELY DISCONNECT THIS APPARATUS FROM THE AC MAINS, DISCONNECT THE POWER SUPPLY CORD PLUG FROM THE AC RECEPTACLE;
- 17) THE MAINS PLUG OF THE POWER SUPPLY CORD SHALL REMAIN READILY ACCESSIBLE.
- 18) In case of voltage selector make sure the switch on the rear panel is on the correct voltage before connecting it to the AC power, and the fuse is the right value for that voltage (This selector is not available on the 100V version).  
Please change the voltage/fuse values label located near the voltage selector matching the voltage/fuse values when you need to change the voltage of the apparatus.
- 19) "WARNING: THIS APPARATUS MUST BE SECURELY ATTACHED TO THE FLOOR OR WALL IN ACCORDANCE WITH INSTALLATION INSTRUCTION. TIPPING, SHAKING, OR ROCKING THE MACHINE MAY CAUSE INJURY OR DEATH."
- 20) "CAUTION: THESE SERVICING INSTRUCTIONS ARE FOR USE BY QUALIFIED SERVICE PERSONNEL ONLY. TO REDUCE THE RISK OF ELECTRIC SHOCK DO NOT PERFORM ANY SERVICING OTHER THAN THAT CONTAINED IN THE OPERATING INSTRUCTIONS UNLESS YOU ARE QUALIFIED TO DO SO"



## MORE INFORMATION

For warranty and service information, please contact your local Markbass distributor (contact information available at [www.markbass.it](http://www.markbass.it)). For more technical information, please visit us at [www.markbass.it](http://www.markbass.it) and fill out the form on the Support page. We hope you enjoy your power amp and use it to make great music!



"The Lightning Flash with arrowhead symbol within an equilateral triangle, is intended to alert the user to the presence of uninsulated "dangerous voltage" within the product enclosure that may be of sufficient magnitude to constitute a risk of shock to persons."



"The exclamation point within an equilateral triangle is intended to alert the user to the presence of important operating and maintenance (servicing) instructions in the literature accompanying the product."



"To be used only with altitude not exceeding 2000 m"



"To be used only where the climate is not tropical"



## PRÉCAUTIONS D'EMPLOI

- 1) Lire ces instructions;
- 2) Conserver ces instructions;
- 3) Suivre tous les conseils d'utilisations;
- 4) Suivre toutes les instructions;
- 5) Ne pas utiliser cet appareil au bord de l'eau;
- 6) Nettoyer uniquement avec un chiffon humide;
- 7) Ne pas bloquer le système de ventilation. Installer conformément aux instructions du fabricant;
- 8) Ne pas installer l'appareil près d'une source de chaleur tel qu'un radiateur, un fourneau, ou bien un autre appareil qui produit de la chaleur;
- 9) Ne pas modifier le système de sécurité de la fiche polarisée ou de la fiche pour les prises de terre. Une fiche polarisée a deux broches, l'une étant plus distante de l'autre. Une fiche pour prise de terre a deux broches et une pointe pour la masse. La broche plus distante et la pointe pour la masse ont été installées pour votre sécurité. Si la fiche fournie de rentre pas dans votre prise de courant consulter un électricien pour la substitution;
- 10) Protéger le cordon d'alimentation afin qu'il ne soit pas piétiné ou écrasé tout particulièrement au niveau des fiches, des prises de courant femelles, et des parties qui sortent de l'appareil;
- 11) Utiliser uniquement les accessoires recommandés par le fabricant;
- 12) Utilisez uniquement avec le chariot, le socle, le trépied, le support ou la table spécifiés par le fabricant ou vendu avec l'appareil.  
Lorsque vous utilisez un chariot, soyez prudent lorsque vous déplacez l'ensemble chariot / appareil pour éviter toute blessure du renversement (et la figure 21 DU Tipping panier Symbol).
- 13) Ne pas branché l'appareil en cas d'orage accompagné d'éclairs. Le débrancher en cas de non utilisation prolongée;
- 14) S'adresser à un service assistance agréé si l'appareil a subi des dommages, si le cordon d'alimentation ou la fiche a été endommagé, si un liquide a été renversé sur l'appareil ou bien si un objet est tombé dans l'appareil, si ce dernier a été exposé à la pluie ou à l'humidité, s'il ne fonctionne pas correctement ou s'il est tombé;
- 15) "AVERTISSANT: POUR RÉDUIRE LE RISQUE DU FEU OU DE DÉCHARGE ÉLECTRIQUE, N'EXPOSEZ PAS CET APPAREIL À LA PLUIE OU L'HUMIDITÉ ET LES OBJETS REMPLIS DE LIQUIDES; TELS QUE DES VASES, NE DEVRAIENT PAS ÊTRE PLACÉS SUR CET APPAREIL";
- 16) POUR DÉCONNECTER COMPLETEMENT L'APPAREIL DU RESEAU D'ALIMENTATION, DÉCONNECTER LE CORDON D'ALIMENTATION DE LA PRISE MURALE;
- 17) LA PRISE DU RESEAU D'ALIMENTATION DOIT DEMEURER AISEMENT ACCESSIBLE.
- 18) En cas de sélecteur de tension s'assurer que l'interrupteur sur le panneau arrière est sur la bonne tension avant de le raccorder à l'alimentation secteur et le fusible est la bonne valeur pour que la tension (Ce sélecteur n'est pas disponible sur la version 100V). S'il vous plaît changer la tension / valeurs de fusibles étiquette située près du sélecteur de tension correspondant aux valeurs / fusibles de tension lorsque vous avez besoin de changer la tension de l'appareil.
- 19) "AVERTISSEMENT: CET APPAREIL DOIT ÊTRE ASSUJÉTI AU PLANCHER OU AU MUR CONFORMÉMENT AUX INSTRUCTIONS D'INSTALLATION. LE FAIT DE L'INCLINER, DE LE BALANÇER OU DE L'AGITER PEUT CAUSER DES BLESSURES OU LA MORT."
- 20) "ATTENTION: CES INSTRUCTIONS D'ENTRETIEN SONT DESTINÉES PAR PERSONNEL QUALIFIÉ SEULEMENT . POUR RÉDUIRE LE RISQUE DE CHOC ÉLECTRIQUE NE PAS EFFECTUER TOUT ENTRETIEN AUTRE QUE CELLES CONTENUES DANS TEH MODE D'EMPLOI SAUF SI VOUS ÊTES QUALIFIÉ POUR LE FAIRE"

# MARK VINTAGE PRE



After the huge success of the Little Mark Vintage head, marking a **new Markbass era**, we designed the **MARK VINTAGE PRE**, a new **tube preamp** pedal, REAL TRUE BYPASS, ready to become a must have tool for **pro bass players**.

MARK VINTAGE PRE delivers a very wide palette of tone options, from **modern** sounds to **vintage** ones and many other features to satisfy any needs.

**4 band EQ, 3-way switch** with preset EQ settings, **DRIVE** control with two types of distortion that can be mixed with the clean signal thanks to the **BLEND** control, +6 dB **BOOST**, **AUX-IN** and **Headphones output**, **FX send/return**, **DI-LINE OUT** with a **dedicated transformer** and, starting from an idea suggested by our top artist Marcus Miller, on this pedal we added the **digital outputs** RCA (with transformer) and TOSLINK with sampling rate switch 44.1/48/96KHz, making it the **perfect studio tool** for recording bass players. A **state of the art** piece of gear letting everybody get a **quality pro sound** everywhere, from **studio** work to **stage** concerts.

This manual will help you get the most out of your MARK VINTAGE PRE.

If you have any questions after reading it, please feel free to contact our Online Customer Service Department at [info@markbass.it](mailto:info@markbass.it).

Thank you again, and enjoy your **MARK VINTAGE PRE!**

# FUNCTIONS OVERVIEW MARK VINTAGE PRE

**GAIN (1)** - determines how much signal is sent through the preamp tube section.

**DRIVE (2)** - controls the amount of drive tone, ranging from crunchy overdrive to aggressive distortion (DRIVE switch allows to select two types of distortion)

**MASTER (3)** - controls the overall preamp volume

**BLEND (4)** - This control allows to mix the DRIVE tone with the CLEAN signal of the tube preamp. Adding a bit of distortion during a studio recording gives a 'gorgeous' bass sound perfectly cutting in the mix; this is one of the tricks often used by professionals during studio recordings.

**LOW (5)** - The LOW EQ control is set to a center frequency of 70 Hz. That means it either boosts or cuts the volume of the frequencies around 70 Hz, to a maximum of 16 decibels.

**MID LOW (6)** - The MID LOW EQ control is set to a center frequency of 400 Hz, boosts or cuts the frequencies around 400 Hz, by as much as 16 decibels.

**MID HIGH (7)** - The MID LOW EQ control is set to a center frequency of 2.5 KHz, boosts or cuts the frequencies around 2.5 KHz, by as much as 16 decibels.

**HIGH (8)** - The MID LOW EQ control is set to a center frequency of 10 KHz, boosts or cuts the frequencies around 10KHz, by as much as 16 decibels.

**3-WAY SWITCH (9)** - This switch gives three useful EQ preset options to get very quickly a real FLAT setting, a CUT one with scooped Mids and enhanced Low and High and an OLD one with scooped High to get an old vintage style tone.

**AUX IN (10)** - Use this input to plug in an iPod, CD or MP3 player using a mini plug 1/8". This signal mixes in evenly with your instrument input.

**PHONES (11)** - For quiet practicing plug headphones into this mini plug 1/8" input. You can practice anywhere and anytime you like.

**LED (RED/GREEN) - FUNCTIONS INDICATOR (12)**

NO COLOR -> Off

GREEN -> On

RED -> Boost ON

GREEN blink -> Drive ON

RED blink -> Drive ON, Boost ON

TUBE LED blink fast -> Clip

TUBE LED 100msec pulse -> Dist type1

TUBE LED 2 (blink) x 100msec pulse -> Dist type2

**DRIVE switch (13)** - allows to activate the drive section and selects two types of distortion holding the button until the TUBE LED turns off, after that the TUBE LED will blink with a different pulse depending on the selected distortion type as described in point 12. Type 1 features a scooped tone to get a pure distortion and Type 2 is designed mainly to increase the sustain, particularly useful in pop/rock tone.

**ON switch (14)** - turns the preamp on and off; the LED indicator is green when the effect is on.

This pedal features "true bypass" circuit: that means when the MARK VINTAGE PRE is 'off', there will be no audio signal quality loss.

**BOOST switch (15)** - It allows you to boost your signal level to +6 dB, to instantly get more headroom whenever you need it, for example it helps you stand out while taking a solo.

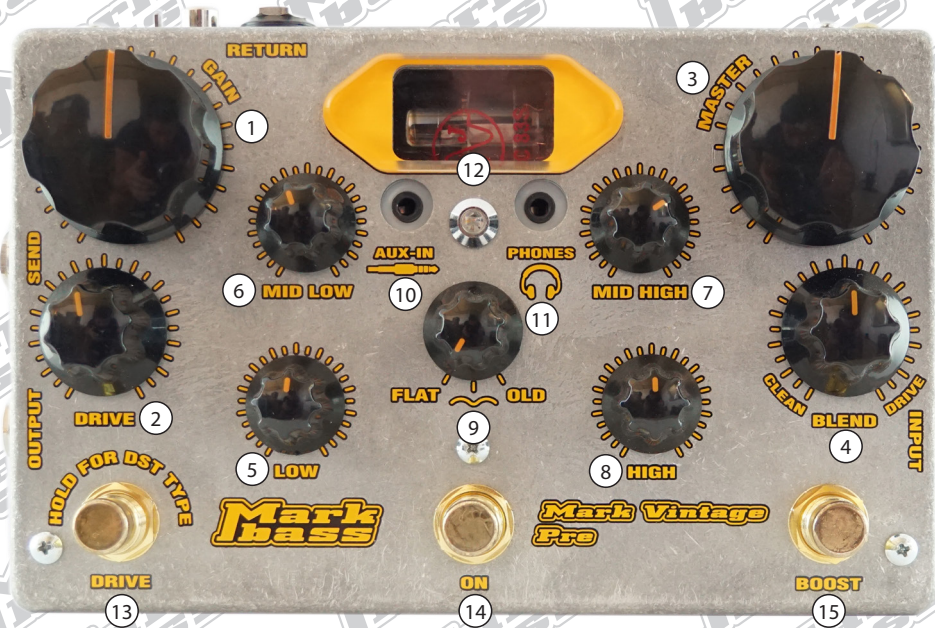

# CONNECTIONS MARK VINTAGE PRE

**1/4" INPUT JACK (16)** - The input jack accepts an unbalanced signal from your bass via a standard 1/4" instrument cable.

**1/4" OUTPUT JACK (17)** - This output can be connected to power amp, powered cabinet and unbalanced input of other devices via a standard 1/4" instrument cable.

**SEND/RETURN (18-19)** - The send/return FX loop allows to interface your favorite stomp boxes and multieffect units to the MARK VINTAGE PRE, connecting the send to the effect input and the return to the effect output via standard 1/4" instrument cables.

**XLR LINE OUT (20)** - The BALANCED LINE OUT is a real DI box with transformer, it is optimized to give pure, full, rich sound on all frequencies, handling extreme transients without introducing any distortion or coloration.

**DIGITAL OUT (21)** - Developed from an idea suggested by our top artist Marcus Miller who was looking for a small, professional unit for studio recordings, we featured the digital outputs RCA (with transformer) and TOSLINK with sampling rate switch 44.1/48/96KHz, making it the perfect studio tool for recording bass players. With the MARK VINTAGE PRE you can get a quality pro sound everywhere, from studio work to stage concerts.

**DC IN (22)** - External power supply connection 12VDC / Power requirement only 300mA

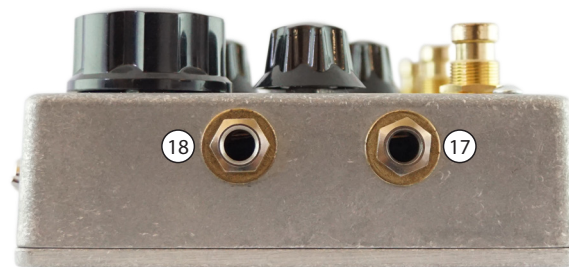

# TECH SPECS MARK VINTAGE PRE

## TUBE

12AX7 (ECC 83)

## INPUT

Impedance 1MΩ, max. voltage 6 Vpp

## GAIN RANGE

-46 ÷ +23 dB

## EQ

LOW: Level ±16 dB (Freq. 70Hz)

MID LOW: Level ±16 dB (Freq. 400 Hz)

MID HIGH: Level ±16 dB (Freq. 2.5 KHz)

HIGH: Level ±16 dB (Freq. 10 KHz)

**3-WAY switch** (FLAT / CUT / OLD)

## CONTROLS

GAIN | MASTER | DRIVE | BLEND

## SWITCHES

ON/OFF | DRIVE | BOOST

## OUTPUTS

UNBALANCED 1/4" JACK

BALANCED DI OUT with transformer (GND switch)

DIGITAL OUTPUTS: RCA (with transformer) and TOSLINK with sampling rate switch 44.1/48/96KHz

## POWER REQUIREMENT

12VDC | 300mA (power supply included)

## DIMENSIONS (W/D/H)

7.6" x 5" x 2.32" | 19.3cm x 12.7cm x 5.9cm

## WEIGHT

1.9 lbs | 840gr

BLOCK DIAGRAM

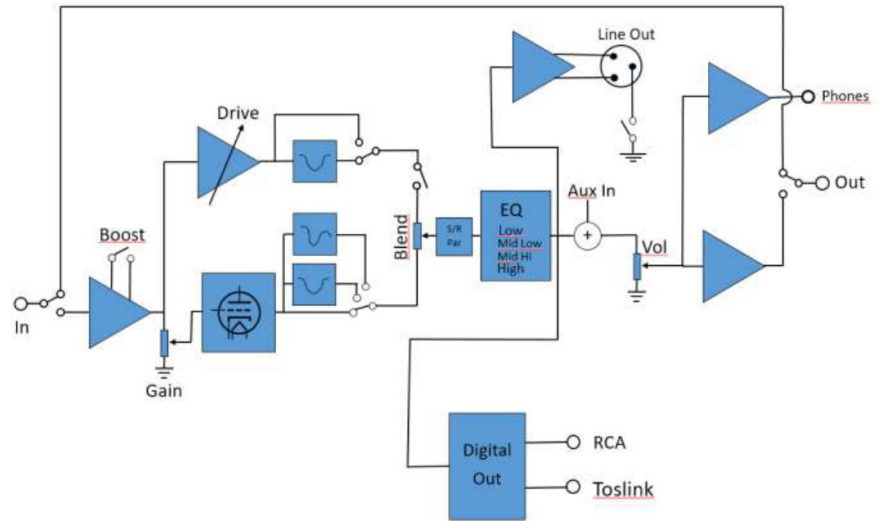

Product specifications are subject to change without notice

A black and white photograph of a Markbass guitar pedal. The pedal is a rectangular metal box with various knobs and switches. The knobs are labeled 'RETURN', 'MID LOW', 'LOW', 'DRIVE', 'MID HIGH', 'FLAT', and 'OLD'. There are also switches for 'AUX IN', 'POWER', and 'ON'. A large, stylized logo for 'Markbass' is overlaid in the center of the image. The logo is yellow and orange with a black outline. The background shows a guitar's fretboard and strings.

**Markbass**

Italy - 66020 San Giovanni Teatino (Ch) - Via Po, 52 - Tel. +39 085 446 3755 - Fax +39 085 440 7764 -  
[www.markbass.it](http://www.markbass.it) - [info@markbass.it](mailto:info@markbass.it)